

Quick Spec:

Part Number: [QDD-400G-ZR4-FL](#)
[QDD-400G-ZR4-EXT-FL](#)
[QDD-400G-ZR4-IND-FL](#)
[QDD-400G-ZR4-FLT](#)
[QDD-400G-ZR4-EXT-FLT](#)
[QDD-400G-ZR4-IND-FLT](#)

Form Factor: QSFP56-DD
TX Wavelength: 1310nm
Reach: 80km
Cable Type: SMF
Rate Category: 400GBase
Interface Type: ZR4
DDM: Yes
Connector Type: Dual-LC



Juniper Compatible QDD-400G-ZR4-FL Features

- QSFP56-DD MSA compliant
- Flex-grid channel spacing DWDM in C-band
- Client-side Interfaces: 400GAUI-8
- Line-side DP-16QAM with CFEC
- QSFP56-DD type 2A form factor
- RoHS compliant
- Operating Case Temperature
 - Standard: 0°C to +70 °C
 - Extended -5°C to +85 °C
 - Industrial -40°C to +85 °C

Juniper Compatible QDD-400G-ZR4-FL Applications

- Data Center Interconnect
- 400G Ethernet
- Infiniband interconnects
- Enterprise networking

Juniper Compatible QDD-400G-ZR4-FL General Description

This product uses a 76-pin QSFP56-DD MSA QSFP56-DD Hardware Specification connector for all electrical interfaces with the host card, whereas the optical interfaces on the line side are provided through the optical receptacles on the QSFP56-DD. The module can be portioned into three functional parts: TX path, RX path and Control & Power block

The host interface is comprised of a total of 8 high-speed SerDes lanes. This allows module to support one interfaces for 400G application: an independent double 4-Lane mode client interfaces (for 400GbE application).

Absolute Maximum Ratings

Parameter	Min.	Max.	Units	Note
Storage Temperature	-40	85	C	
Storage Humidity (Relative)	-	85	%	no-condensation
Case Temperature	-5	75	C	
Operating Humidity (Relative)	-	85	%	no-condensation
Short term Operating Case Temperature		75	C	
Power Supply Voltage	-0.3	3.63	V	
RX Optical Maximum Input Power	-	10	dBm	

Operating Conditions

Parameter	Min.	Max.	Units	Note
Operating Case Temperature	0	70	C	
Operating Humidity (Relative)		85	%	no-condensation
Power Supply Operating Range	3.135	3.465	V	
RX Optical Input Power	-	0	dBm	

Power Supply Specifications

Parameter	Min.	Typ	Max.	Units	Note
3.3V DC Power Supply Voltage	3.135	3.3	3.465	V	
3.3V DC Power Supply Current			7	A	
Power Dissipation			18.5	W	
Low Power Consumption			1.0	W	
Module Inrush Current			100	mA/us	
Turn-off Current	-100			mA/us	
Power Supply Noise			25	mV	

Low Speed Control and Sense Signals

Parameter	Symbol	Min	Max	Unit	Condition
SCL and SDA	VOL	0	0.4	V	IOL(max)=3 mA for fast mode, 20 mA for Fast-mode plus
SCL and SDA	VIL	-0.3	V _{cc} * 0.3	V	
	VIH	V _{cc} * 0.7	V _{cc} + 0.5	V	
Capacitance for SCL and SDA I/O signal	Ci		14	pF	
Total bus capacitive load for SCL and SDA	Cb		100	pF	For 300 kHz clock rate use 3.0k Ohms Pull-up resistor, max
			200	pF	For 300 kHz clock rate use 3.0k Ohms Pull-up resistor, max
LPMode, ResetL, ModSelL and ePPS	VIL	-0.3	0.8	V	
	VIH	2	V _{cc} + 0.3	V	
LPMode, ResetL and ModSelL	I _{in}		360	uA	0V < V _{in} < V _{cc}
ePPS	I _{in}		TBD	uA	0V < V _{in} < V _{cc}
IntL	VOL	0	0.4	V	IOL=2.0 mA
	VOH	V _{cc} - 0.5	V _{cc} + 0.3	V	10k Ohms pull-up tp Host V _{cc}
ModPrsL	VOL	0	0.4	V	IOL=2.0 mA
	VOH			V	ModPrsL can be implemented as a short-circuit to GND on the module

Transceiver Block Diagram

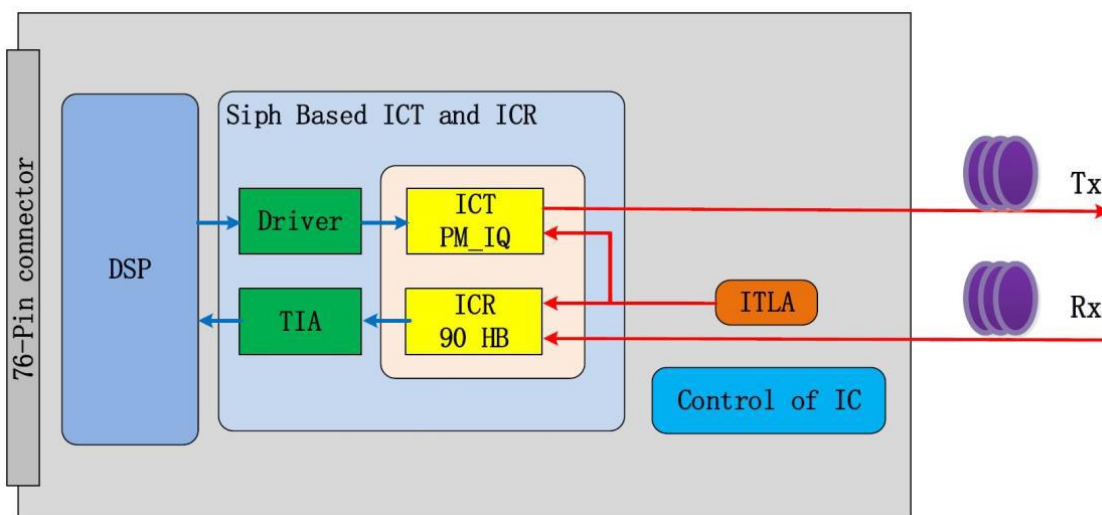

Optical Transmitter Specifications

Parameter	Min.	Typ.	Max.	Units	Note
Transmitter Frequency Range	191.3	193.7	196.1	THz	C band 75GHz ITU-T grid. Frequency range over which the specifications hold unless noted otherwise
Laser Frequency Stability	-1.8		1.8	GHz	Frequency stability relative to ITU grid
Laser Frequency Accuracy	-1.8		1.8	GHz	
Laser Frequency Fine Tuning Range	-6.0		6.0	GHz	
Fine Tuning Resolution		100		MHz	
Channel Tuning Speed	-		60	S	
Laser Line Width			300	kHz	
Transmitter Output Power Range		-11.5		dBm	
Transmitter Laser Disable Time			180	Ms	
Output Power Stability	-0.5		0.5	dB	Difference over temperature, time, wavelength and aging
Output Power Accuracy	-2		2	dB	Difference between the set value and actual value over aging
Transmitter Turn-up Time from Cold Start	-		100	S	
Transmitter OSNR (Inband)	34		-	dB/0.1m m	
Transmitter Back Reflectance	-		-24	dB	
Transmitter Output Power with TX Disabled	-		-20	dBm	
Transmitter Polarization Dependent Power	-		1.5	dB	Power difference between X and Y polarization

Optical Receiver Specifications

Parameter	Min.	Typ.	Max.	Units	Note
Receiver Frequency Range	191.3	193.7	196.1	THz	
Input Power Range	-12		0	dBm	Signal power of the channel at the OSNR Penalty < 0.5dB
OSNR Sensitivity			26	dB/0.1nm	
Receiver Sensitivity	-20			dBm	Input power needed to achieve postFEC BER < 1E-15 when OSNR Tolerance > 26dB/0.1nm
Los Assert	-20	-18	-16	dBm	
Los Hysteresis	1.0		2.5	dB	
CD Tolerance	2400			ps/nm	Tolerance to Chromatic Dispersion
DGD Tolerance	10			ps	Tolerance to PMD with < 0.5 dB penalty to OSNR sensitivity
Peak PDL Tolerance	3.5			dB	Tolerance to peak PDL with < 1.3 dB penalty to OSNR sensitivity when change in SOP is < =1 rad/ms
Tolerance to Change in SOP	50		-	rad/ms	
Input Power Transient Tolerance	-2		2	dB	Tolerance to change in input power with < 0.5 dB penalty to OSNR sensitivity
Input Power Reading Accuracy	-2		2	dB	
Optical Return Loss	-20			dB	Optical reflectance at Rx connector input
Receiver Turn-up Time from Cold Start	-		100	s	From module reset, with valid optical input signal present

Electrical Characteristics for Transmitter

Parameter	Min.	Typ.	Max.	Units	Note
Signal Rate, each Lane		26.5625±100ppm		GBaud	
Different Peak-Peak Input Voltage Tolerance			900	mVpp	

Electrical Characteristics for Receiver

Parameter	Min.	Typ.	Max.	Units	Note
Signal Rate, each Lane		26.5625±100ppm		GBaud	
Different Peak-Peak Input Voltage Tolerance		750	900	mVpp	
Transition Time, 20% to 80%		9.5		ps	

Pin Assignment and Description

The electrical pinout of the QSFP56-DD module is shown in Figure 2 below.

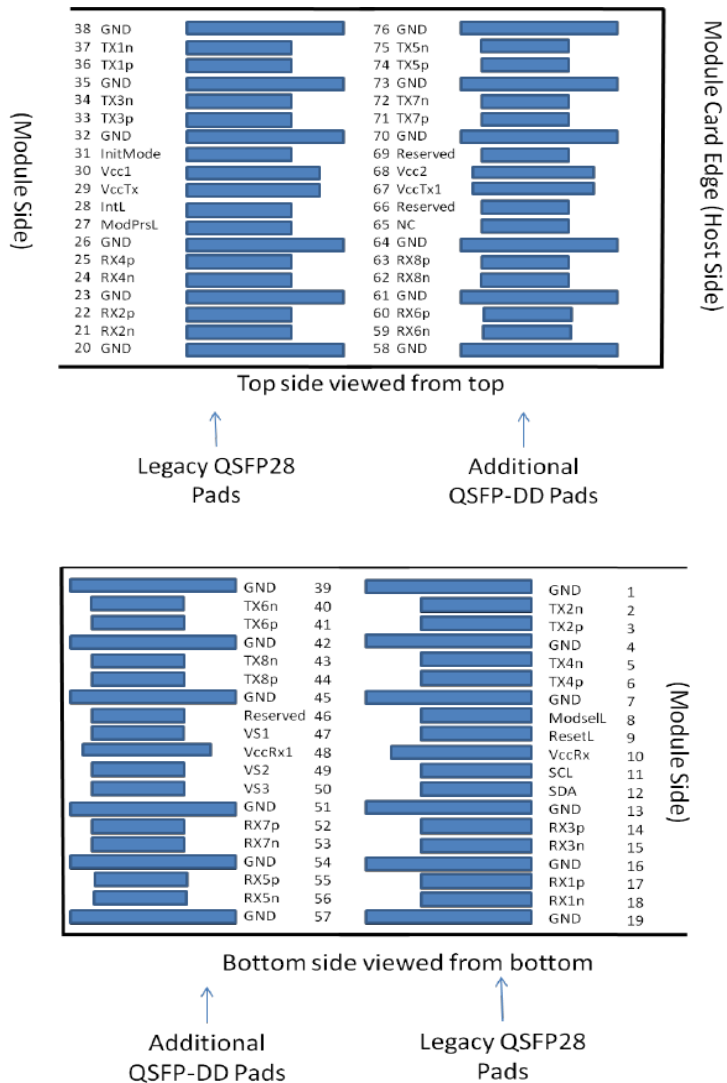

Figure 2. MSA Compliant Connector

Pin Definition

Pin	Logic	Symbol	Description	Plug Sequence
1		GND	Ground	1B
2	CML-I	Tx2n	Transmitter Inverted Data Input	3B
3	CML-I	Tx2p	Transmitter Non-Inverted Data Input	3B
4		GND	Ground	1B
5	CML-I	Tx4n	Transmitter Inverted Data Input	3B
6	CML-I	Tx4p	Transmitter Non-Inverted Data Input	3B
7		GND	Ground	1B
8	LVTTL-I	ModSelL	Module Select	3B
9	LVTTL-I	ResetL	Module Reset	3B
10		VccRx	+3.3V Power Supply Receiver	2B
11	LVC MOS-I/O	SCL	2-wire serial interface clock	3B
12	LVC MOS-I/O	SDA	2-wire serial interface data	3B
13		GND	Ground	1B
14	CML-O	Rx3p	Receiver Non-Inverted Data Output	3B
15	CML-O	Rx3n	Receiver Inverted Data Output	3B
16		GND	Ground	1B
17	CML-O	Rx1p	Receiver Non-Inverted Data Output	3B
18	CML-O	Rx1n	Receiver Inverted Data Output	3B
19		GND	Ground	1B
20		GND	Ground	1B
21	CML-O	Rx2n	Receiver Inverted Data Output	3B
22	CML-O	Rx2p	Receiver Non-Inverted Data Output	3B
23		GND	Ground	1B
24	CML-O	Rx4n	Receiver Inverted Data Output	3B
25	CML-O	Rx4p	Receiver Non-Inverted Data Output	3B
26		GND	Ground	1B
27	LVTTL-O	ModPrsL	Module Present	3B
28	LVTTL-O	IntL	Interrupt	3B
29		VccTx	+3.3V Power supply transmitter	2B
30		Vcc1	+3.3V Power supply	2B
31	LVTTL-I	InitMode	Initialization mode; In legacy QSFP applications, the InitMode pad is called LPMODE	3B
32		GND	Ground	1B

33	CML-I	Tx3p	Transmitter Non-Inverted Data Input	3B
34	CML-I	Tx3n	Transmitter Inverted Data Input	3B
35		GND	Ground	1B
36	CML-I	Tx1p	Transmitter Non-Inverted Data Input	3B
37	CML-I	Tx1n	Transmitter Inverted Data Input	3B
38		GND	Ground	1B
39		GND	Ground	1A
40	CML-I	Tx6n	Transmitter Inverted Data Input	3A
41	CML-I	Tx6p	Transmitter Non-Inverted Data Input	3A
42		GND	Ground	1A
43	CML-I	Tx8n	Transmitter Inverted Data Input	3A
44	CML-I	Tx8p	Transmitter Non-Inverted Data Input	3A
45		GND	Ground	1A
46		Reserved	For future use	3A
47		VS1	Module Vendor Specific 1	3A
48		VccRx1	3.3V Power Supply	2A
49		VS2	Module Vendor Specific 2	3A
50		VS3	Module Vendor Specific 3	3A
51		GND	Ground	1A
52	CML-O	Rx7p	Receiver Non-Inverted Data Output	3A
53	CML-O	Rx7n	Receiver Inverted Data Output	3A
54		GND	Ground	1A
55	CML-O	Rx5p	Receiver Non-Inverted Data Output	3A
56	CML-O	Rx5n	Receiver Inverted Data Output	3A
57		GND	Ground	1A
58		GND	Ground	1A
59	CML-O	Rx6n	Receiver Inverted Data Output	3A
60	CML-O	Rx6p	Receiver Non-Inverted Data Output	3A
61		GND	Ground	1A
62	CML-O	Rx8n	Receiver Inverted Data Output	3A
63	CML-O	Rx8p	Receiver Non-Inverted Data Output	3A
64		GND	Ground	1A
65		NC	No Connect	3A
66		Reserved	For future use	3A
67		VccTx1	3.3V Power Supply	2A
68		Vcc2	3.3V Power Supply	2A
69		Reserved	For Future Use	3A
70		GND	Ground	1A

71	CML-I	Tx7p	Transmitter Non-Inverted Data Input	3A
72	CML-I	Tx7n	Transmitter Inverted Data Input	3A
73		GND	Ground	1A
74	CML-I	Tx5p	Transmitter Non-Inverted Data Input	3A
75	CML-I	Tx5n	Transmitter Inverted Data Input	3A
76		GND	Ground	1A

Digital Diagnostic Functions

The following digital diagnostic characteristics are defined over the normal operating conditions unless otherwise specified.

Parameter	Symbol	Min	Max	Units	Notes
Temperature monitor absolute error	DMI_Temp	-3	3	degC	Over operating temperature range
Supply voltage monitor absolute error	DMI_VCC	-0.1	0.1	V	Over full operating range
Channel RX power monitor absolute error	DMI_RX_Ch	-2	2	dB	1
Channel Bias current monitor	DMI_Ibias_Ch	-10%	10%	mA	
Channel TX power monitor absolute error	DMI_TX_Ch	-2	2	dB	1

Notes:

1. Due to measurement accuracy of different single mode fibers, there could be an additional +/-1 dB fluctuation, or a +/- 3 dB total accuracy.

Mechanical Dimensions

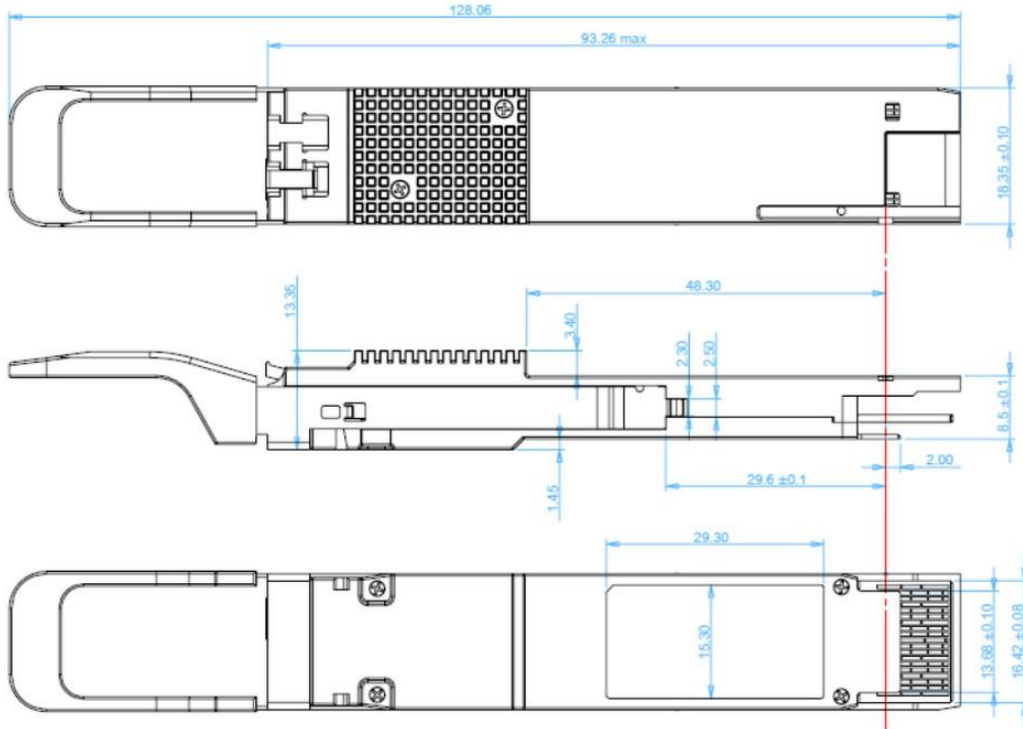

ESD

This transceiver is specified as ESD threshold 1kV for high speed data pins and 2kV for all other electrical input pins, tested per MIL-STD-883, Method 3015.4 /JESD22- A114-A (HBM). However, normal ESD precautions are still required during the handling of this module. This transceiver is shipped in ESD protective packaging. It should be removed from the packaging and handled only in an ESD protected environment.

Laser Safety

This is a Class 1 Laser Product according to EN 60825-1:2014. This product complies with 21 CFR 1040.10 and 1040.11 except for deviations pursuant to Laser Notice No. 50, dated (June 24, 2007).

Caution: Use of controls or adjustments or performance of procedures other than those specified herein may result in hazardous radiation exposure.

Licensing

The following U.S. patents are licensed by Finisar to FluxLight, Inc.:

U.S. Patent Nos: 7,184,668, 7,079,775, 6,957,021, 7,058,310, 6,952,531, 7,162,160, 7,050,720