

Quick Spec:

Part Number: [QDD-400G-SR8-S-FL](#)
[QDD-400G-SR8-S-EXT-FL](#)
[QDD-400G-SR8-S-IND-FL](#)
[QDD-400G-SR8-S-FLT](#)
[QDD-400G-SR8-S-EXT-FLT](#)
[QDD-400G-SR8-S-IND-FLT](#)

Form Factor: QSFP56-DD
TX Wavelength: 850nm
Reach: 70m
Cable Type: MMF
Rate Category: 400GBase
Interface Type: SR8
DDM: Yes
Connector Type: MPO-16



Cisco Compatible QDD-400G-SR8-S-FLT Features

- QSFP56-DD MSA compliant
- 8 parallel lanes on 850nm center wavelength
- Compliant to IEEE 802.3bs Specification
- Up to 70m transmission on multi-mode fiber(MMF) OM3 with FEC
- 8x53.125Gb/s electrical interface (400GAUI-8)
- Data Rate 53.125Gbps (PAM4) per channel.
- Maximum power consumption 11W
- MPO-16 connector
- RoHS compliant
- Operating Case Temperature
 - Standard: 0°C to +70 °C
 - Extended -5°C to +85 °C
 - Industrial -40°C to +85 °C

Cisco Compatible QDD-400G-SR8-S-FLT Applications

- 400G Ethernet
- Infiniband interconnects
- Datacenter Enterprise networking

Cisco Compatible QDD-400G-SR8-S-FLT General Description

This product is a parallel 400Gb/s Quad Small Form Factor Pluggable--double density (QSFP56-DD) optical module. It provides increased port density and total system cost savings. The QSFP56-DD full-duplex optical module offers 8 independent transmit and receive channels, each capable of 53.125Gb/s operation for an aggregate data rate of 400Gb/s on 100 meters of OM3 multi-mode fiber.

An optical fiber cable with an MTP/MPO-16 connector can be plugged into the QSFP56-DD SR8 module receptacle. Proper alignment is ensured by the guide pins inside the receptacle. The cable usually cannot be twisted for proper channel to channel alignment. Electrical connection is achieved through an QSFP56-DD MSA-compliant edge type connector.

The central wavelengths of all the 8 parallel lanes are 850nm. It contains an optical MPO-16 connector for the optical interface and a 60-pin connector for the electrical interface. Host FEC is required to support up to 70m OM3 multi-mode fiber transmission.

The product is designed with form factor, optical/electrical connection and digital diagnostic interface according to the QSFP56-DD Multi-Source Agreement (MSA) Type 2. It has been designed to meet the harshest external operating conditions including temperature, humidity and EMI interference.

Cisco Compatible QDD-400G-SR8-S-FLT Functional Description

The module incorporates 8 parallel channels, on 850nm Center Wavelength, operating at 50G per channel. The transmitter path incorporates an 8-channel CDR retimer, 2 sets of quad channel VCSEL drivers together with 2 sets of VCSEL arrays. On the receiver path, 2 sets of photodiode arrays optics are coupled with an 8-channel CDR retimer. The electrical interface is compliant with IEEE 802.3bs and QSFP56-DD MSA in the transmitting and receiving directions, and the optical interface is compliant to QSFP56-DD MSA with MPO-16 Optical Connector. Figure 1 shows the functional block diagram of this product.

A single +3.3V power supply is required to power up this product. All the power supply pins are internally connected and should be applied concurrently. As per MSA specifications the module offers seven low speed hardware control pins (including the 2-wire serial interface): ModSelL, SCL, SDA, ResetL, InitMode, ModPrsL and IntL.

Module Select (ModSelL) is an input pin. When held low by the host, this product responds to 2-wire serial communication commands. The ModSelL allows the use of this product on a single 2-wire interface bus – individual ModSelL lines must be used.

The ResetL pin enables a complete reset, returning the settings to their default state, when a low level on the ResetL pin is held for longer than the minimum pulse length. During the execution of a reset the host shall disregard all status bits until it indicates a completion of the reset interrupt. The product indicates this by posting an IntL (Interrupt) signal with the Data_Not_Ready bit negated in the memory map. Note that on power up (including hot insertion) the module should post this completion of reset interrupt without requiring a reset.

Initialize Mode (InitMode) is an input signal. It is pulled up to Vcc in the QSFP56-DD module. The InitMode signal allows the host to define whether the QSFP56-DD module will initialize under host software control (InitMode asserted High) or module hardware control (InitMode deasserted Low). Under host software control, the module shall remain in Low Power Mode until software enables the transition to High Power Mode, as defined in the QSFP56-DD Management Interface Specification. Under hardware control (InitMode de-asserted Low), the module may immediately transition to High Power Mode after the management interface is initialized. The host shall not change the state of this signal while the module is present. In legacy QSFP applications, this signal is named LPMMode. See SFF-8679 for LPMMode signal description.

Module Present (ModPrsL) is a signal local to the host board which, in the absence of a product, is normally pulled up to the host Vcc. When the product is inserted into the connector, it completes the path to ground through a resistor on the host board and asserts the signal. ModPrsL then indicates its present by setting ModPrsL to a “Low” state.

Interrupt (IntL) is an output pin. “Low” indicates a possible operational fault or a status critical to the host system. The host identifies the source of the interrupt using the 2-wire serial interface. The IntL pin is an open collector output and must be pulled to the Host Vcc voltage on the Host board.

Serial Clock (SCL) and Serial Data (SDA) are required for the 2-wire serial bus communication interface and enable the host to access the memory map.

Transceiver Block Diagram

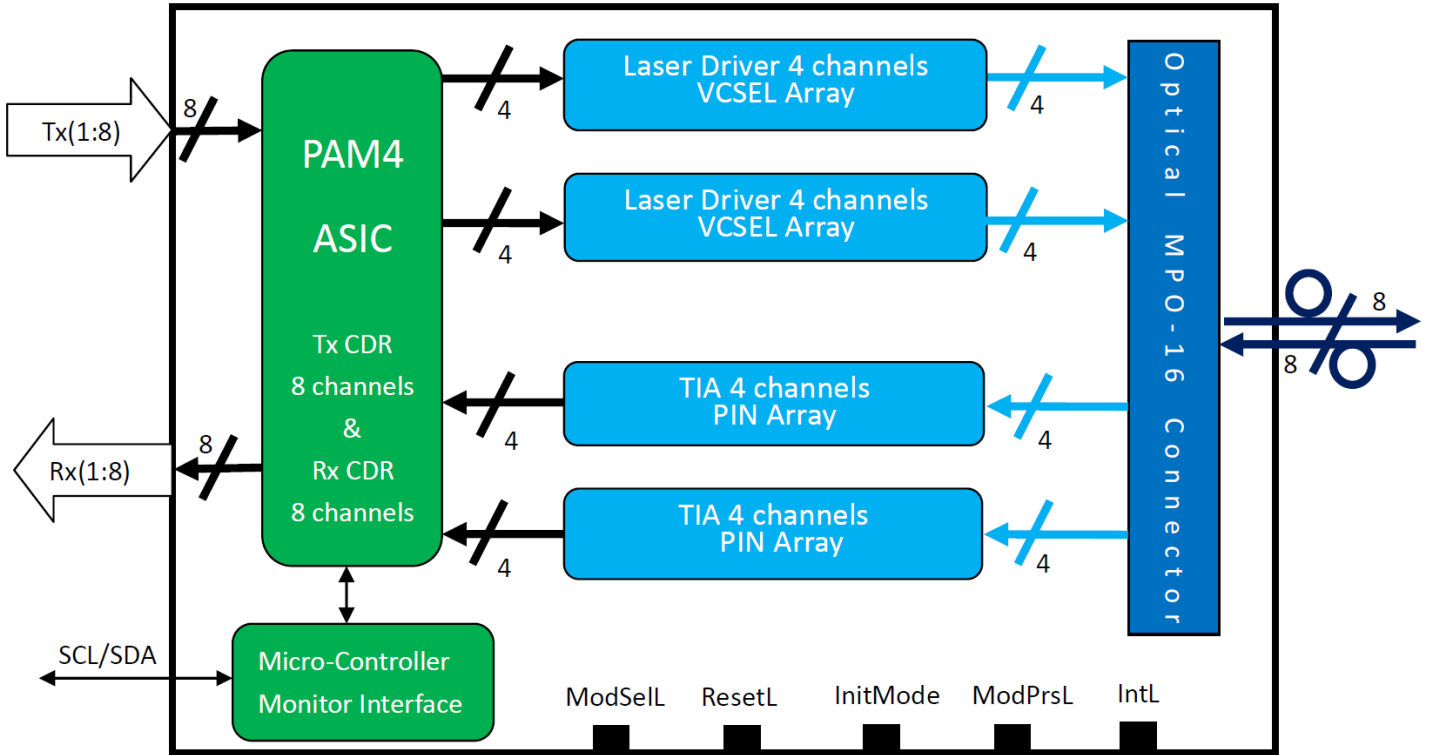

Figure 1. Transceiver Block Diagram

Pin Assignment and Description

The electrical pinout of the QSFP56-DD module is shown as Figure 2. And Figure 3 shows the optical interface of MPO-16.

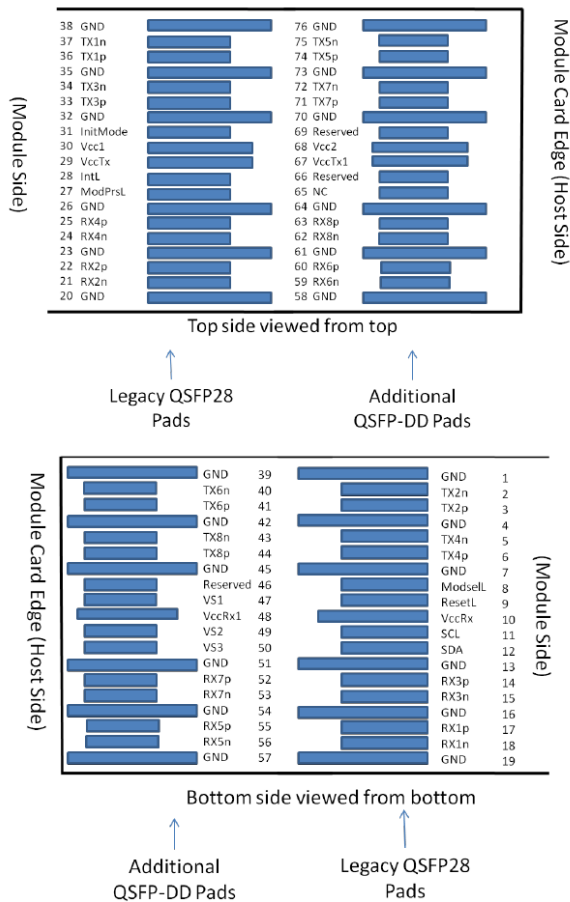

Figure 2. MSA Compliant Connector



Figure 3. MPO-16 Optical connector Interface



Build It Bigger. Build It Faster. Build It Sooner.

Cisco Compatible QDD-400G-SR8-S-FLT
850nm, MPO-16, SR8, MMF, 70m

Pin Definition

Pin	Logic	Symbol	Description	Plug Sequence
1		GND	Ground	1B
2	CML-I	Tx2n	Transmitter Inverted Data Input	3B
3	CML-I	Tx2p	Transmitter Non-Inverted Data Input	3B
4		GND	Ground	1B
5	CML-I	Tx4n	Transmitter Inverted Data Input	3B
6	CML-I	Tx4p	Transmitter Non-Inverted Data Input	3B
7		GND	Ground	1B
8	LVTTL-I	ModSelL	Module Select	3B
9	LVTTL-I	ResetL	Module Reset	3B
10		VccRx	+3.3V Power Supply Receiver	2B
11	LVC MOS - I/O	SCL	2-wire serial interface clock	3B
12	LVC MOS - I/O	SDA	2-wire serial interface data	3B
13		GND	Ground	1B
14	CML-O	Rx3p	Receiver Non-Inverted Data Output	3B
15	CML-O	Rx3n	Receiver Inverted Data Output	3B
16		GND	Ground	1B
17	CML-O	Rx1p	Receiver Non-Inverted Data Output	3B
18	CML-O	Rx1n	Receiver Inverted Data Output	3B
19		GND	Ground	1B
20		GND	Ground	1B
21	CML-O	Rx2n	Receiver Inverted Data Output	3B
22	CML-O	Rx2p	Receiver Non-Inverted Data Output	3B
23		GND	Ground	1B
24	CML-O	Rx4n	Receiver Inverted Data Output	3B
25	CML-O	Rx4p	Receiver Non-Inverted Data Output	3B
26		GND	Ground	1B
27	LVTTL-O	ModPrsL	Module Present	3B
28	LVTTL-O	IntL	Interrupt	3B
29		VccTx	+3.3V Power supply transmitter	2B
30		Vcc1	+3.3V Power supply	2B
31	LVTTL-I	InitMode	Initialization mode; In legacy QSFP applications, the InitMode pad is called LPMODE	3B

32		GND	Ground	1B
33	CML-I	Tx3p	Transmitter Non-Inverted Data Input	3B
34	CML-I	Tx3n	Transmitter Inverted Data Input	3B
35		GND	Ground	1B
36	CML-I	Tx1p	Transmitter Non-Inverted Data Input	3B
37	CML-I	Tx1n	Transmitter Inverted Data Input	3B
38		GND	Ground	1B
39		GND	Ground	1A
40	CML-I	Tx6n	Transmitter Inverted Data Input	3A
41	CML-I	Tx6p	Transmitter Non-Inverted Data Input	3A
42		GND	Ground	1A
43	CML-I	Tx8n	Transmitter Inverted Data Input	3A
44	CML-I	Tx8p	Transmitter Non-Inverted Data Input	3A
45		GND	Ground	1A
46		Reserved	For future use	3A
47		VS1	Module Vendor Specific 1	3A
48		VccRx1	3.3V Power Supply	2A
49		VS2	Module Vendor Specific 2	3A
50		VS3	Module Vendor Specific 3	3A
51		GND	Ground	1A
52	CML-O	Rx7p	Receiver Non-Inverted Data Output	3A
53	CML-O	Rx7n	Receiver Inverted Data Output	3A
54		GND	Ground	1A
55	CML-O	Rx5p	Receiver Non-Inverted Data Output	3A
56	CML-O	Rx5n	Receiver Inverted Data Output	3A
57		GND	Ground	1A
58		GND	Ground	1A
59	CML-O	Rx6n	Receiver Inverted Data Output	3A
60	CML-O	Rx6p	Receiver Non-Inverted Data Output	3A
61		GND	Ground	1A
62	CML-O	Rx8n	Receiver Inverted Data Output	3A
63	CML-O	Rx8p	Receiver Non-Inverted Data Output	3A
64		GND	Ground	1A
65		NC	No Connect	3A
66		Reserved	For future use	3A
67		VccTx1	3.3V Power Supply	2A
68		Vcc2	3.3V Power Supply	2A
69		Reserved	For Future Use	3A
70		GND	Ground	1A

71	CML-I	Tx7p	Transmitter Non-Inverted Data Input	3A
72	CML-I	Tx7n	Transmitter Inverted Data Input	3A
73		GND	Ground	1A
74	CML-I	Tx5p	Transmitter Non-Inverted Data Input	3A
75	CML-I	Tx5n	Transmitter Inverted Data Input	3A
76		GND	Ground	1A

Recommended Power Supply Filter

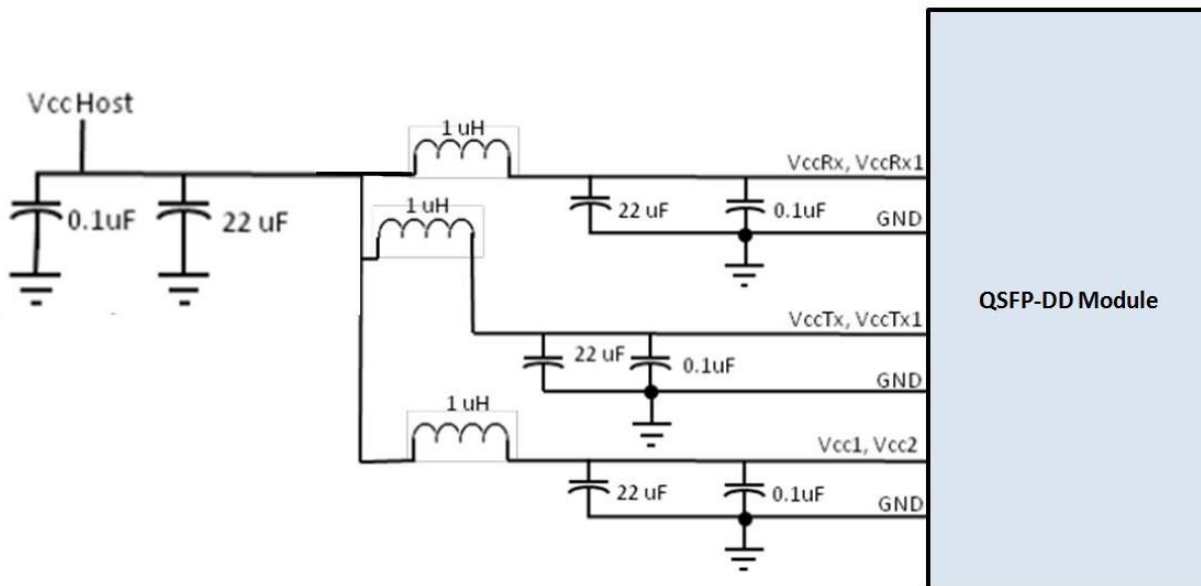

Absolute Maximum Ratings

It has to be noted that the operation in excess of any individual absolute maximum ratings might cause permanent damage to this module.

Parameter	Symbol	Min	Max	Units	Notes
Storage Temperature	T _S	-40	85	degC	
Operating Case Temperature - Commercial	T _{OP}	0	70	degC	
Operating Case Temperature - Industrial	T _{OP}	-40	85	degC	
Power Supply Voltage	V _{CC}	-0.5	3.6	V	
Relative Humidity (non-condensation)	RH	0	85	%	

Recommended Operating Conditions and Power Supply Requirements

Parameter	Symbol	Min	Typical	Max	Units	Notes
Operating Case Temperature	T _{OP}	0		70	degC	
Power Supply Voltage	V _{CC}	3.135	3.3	3.465	V	
Data Rate, each Lane			26.5625		GBd	PAM4
Data Rate Accuracy		-100		100	ppm	
Pre-FEC Bit Error Ratio				2.4x10 ⁻⁴		
Post-FEC Bit Error Ratio				1x10 ⁻¹²		1
Link Distance	D	0.5		500	m	2

Notes:

1. FEC provided by host system.
2. FEC required on host system to support maximum distance.

Electrical Characteristics

The following electrical characteristics are defined over the Recommended Operating Environment unless otherwise specified.

Parameter	Test Point	Min	Typical	Max	Units	Notes
Power Consumption				11	W	
Supply Current	Icc			3.33	A	
Transmitter (each Lane)						
Signaling Rate, each Lane	TP1	26.5625 ± 100 ppm			GBd	
Differential pk-pk Input Voltage Tolerance	TP1a	900			mVpp	1
Differential Termination Mismatch	TP1			10	%	
Differential Input Return Loss	TP1	IEEE 802.3-2015 Equation (83E-5)			dB	
Differential to Common Mode Input Return Loss	TP1	IEEE 802.3-2015 Equation (83E-6)			dB	
Module Stressed Input Test	TP1a	See IEEE 802.3bs 120E.3.4.1				2
Single-ended Voltage Tolerance Range (Min)	TP1a	-0.4 to 3.3			V	
DC Common Mode Input Voltage	TP1	-350		2850	mV	3
Receiver (each Lane)						
Signaling Rate, each lane	TP4	26.5625 ± 100 ppm			GBd	
Differential Peak-to-Peak Output Voltage	TP4			900	mVpp	
AC Common Mode Output Voltage, RMS	TP4			17.5	mV	
Differential Termination Mismatch	TP4			10	%	
Differential Output Return Loss	TP4	IEEE 802.3-2015 Equation (83E-2)				
Common to Differential Mode Conversion Return Loss	TP4	IEEE 802.3-2015 Equation (83E-3)				
Transition Time, 20% to 80%	TP4	9.5			ps	
Near-end Eye Symmetry Mask Width (ESMW)	TP4		0.265		UI	
Near-end Eye Height, Differential	TP4	70			mV	
Far-end Eye Symmetry Mask Width (ESMW)	TP4		0.2		UI	
Far-end Eye Height, Differential	TP4	30			mV	
Far-end Pre-cursor ISI Ratio	TP4	-4.5		2.5	%	
Common Mode Output Voltage (Vcm)	TP4	-350		2850	mV	3

Notes:

1. With the exception to IEEE 802.3bs 120E.3.1.2 that the pattern is PRBS31Q or scrambled idle.
2. Meets BER specified in IEEE 802.3bs 120E.1.1.
3. DC common mode voltage generated by the host. Specification includes effects of ground offset voltage.

Optical Characteristics

Parameter	Symbol	Min	Typical	Max	Units	Notes
Transmitter						
Center Wavelength	λ_c	840	850	860	nm	
Data Rate, each Lane		26.5625 ± 100 ppm			GBd	
Modulation Format		PAM4				
RMS Spectral Width	$\Delta \lambda_{rms}$			0.6	nm	Modulated
Average Launch Power, each Lane	P_{AVG}	-6		4	dBm	1
Outer Optical Modulation Amplitude (OMA_{outer}), each Lane	P_{OMA}	-4		3	dBm	2
Launch Power in OMA_{outer} minus TDECQ, each Lane		-5			dB	
Transmitter and Dispersion Eye Closure for PAM4, each Lane	TDECQ			4	dB	
Extinction Ratio	ER	3			dB	
Optical Return Loss Tolerance	TOL			12	dB	
Average Launch Power of OFF Transmitter, each Lane	P_{off}			-30	dBm	
Encircled Flux		≥ 86% at 19 μ m ≤ 30% at 4.5 μ m				
Receiver						
Center Wavelength	λ_c	840	850	860	nm	
Data Rate, each Lane		26.5625 ± 100 ppm			GBd	
Modulation Format		PAM4				
Damage Threshold, each Lane	TH_d	5			dBm	3
Average Receive Power, each Lane		-7.9		4	dBm	4
Receive Power (OMA_{outer}), each Lane				3	dBm	
Receiver Sensitivity (OMA_{outer}), each Lane	SEN			-7	dBm	5
Stressed Receiver Sensitivity (OMA_{outer}), each Lane	SRS			-3	dBm	6
Receiver Reflectance	RR			-12	dB	
LOS Assert	LOSA	-30			dBm	
LOS De-assert	LOSD			-12	dBm	
LOS Hysteresis	LOSH	0.5			dB	
Stressed Conditions for Stress Receiver Sensitivity (Note 7)						
Stressed Eye Closure for PAM4 (SECQ), Lane under Test			4		dB	
OMA_{outer} of each Aggressor Lane			3		dBm	

Notes:

1. Average launch power, each lane (min) is informative and not the principal indicator of signal strength. A transmitter with launch power below this value cannot be compliant; however, a value above this does not ensure compliance.
2. Even if the TDECQ < 1.4 dB, the OMA_{outer} (min) must exceed the minimum value specified here.
3. The receiver shall be able to tolerate, without damage, continuous exposure to an optical input signal having this average power level.
4. Average receive power, each lane (min) is informative and not the principal indicator of signal strength. A received power below this value cannot be compliant; however, a value above this does not ensure compliance.
5. Receiver sensitivity (OMA_{outer}), each lane (max) is informative and is defined for a transmitter with SECQ of 0.9 dB.
6. Measured with conformance test signal for BER = 2.4×10^{-4} .
7. These test conditions are for measuring stressed receiver sensitivity. They are not characteristics of the receiver.

Digital Diagnostic Functions

The following digital diagnostic characteristics are defined over the normal operating conditions unless otherwise specified.

Parameter	Symbol	Min	Max	Units	Notes
Temperature monitor absolute error	DMI_Temp	-3	3	degC	Over operating temperature range
Supply voltage monitor absolute error	DMI_VCC	-0.1	0.1	V	Over full operating range
Channel RX power monitor absolute error	DMI_RX_Ch	-2	2	dB	1
Channel Bias current monitor	DMI_Ibias_Ch	-10%	10%	mA	
Channel TX power monitor absolute error	DMI_TX_Ch	-2	2	dB	1

Notes:

1. Due to measurement accuracy of different single mode fibers, there could be an additional +/-1 dB fluctuation, or a +/- 3 dB total accuracy.

Mechanical Dimensions

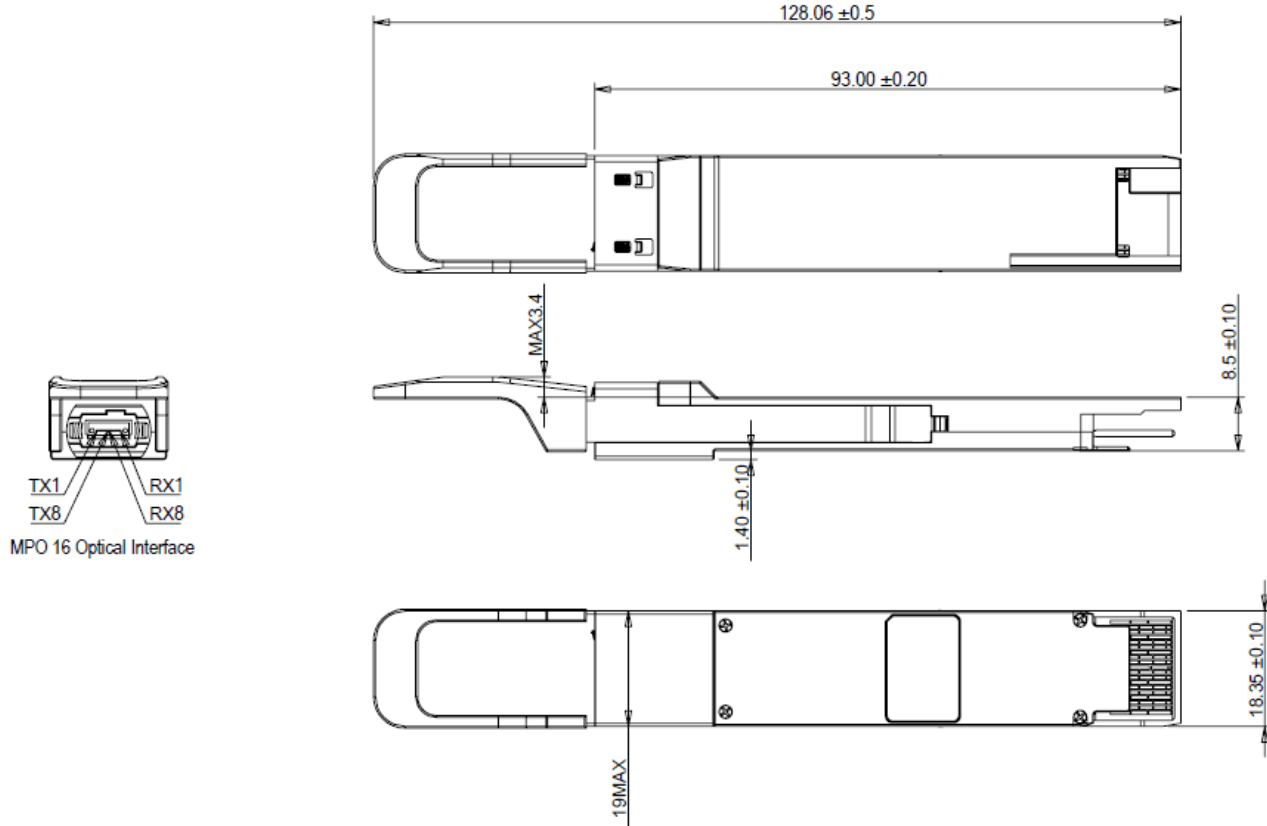

QSFP- DD SR8 MPO 16 Optical Interface Outline

ESD

This transceiver is specified as ESD threshold 1kV for high speed data pins and 2kV for all other electrical input pins, tested per MIL-STD-883, Method 3015.4 /JESD22- A114-A (HBM). However, normal ESD precautions are still required during the handling of this module. This transceiver is shipped in ESD protective packaging. It should be removed from the packaging and handled only in an ESD protected environment.

Laser Safety

This is a Class 1 Laser Product according to EN 60825-1:2014. This product complies with 21 CFR 1040.10 and 1040.11 except for deviations pursuant to Laser Notice No. 50, dated (June 24, 2007).

Caution: Use of controls or adjustments or performance of procedures other than those specified herein may result in hazardous radiation exposure.

Licensing

The following U.S. patents are licensed by Finisar to FluxLight, Inc.:

U.S. Patent Nos: 7,184,668, 7,079,775, 6,957,021, 7,058,310, 6,952,531, 7,162,160, 7,050,720