

Part Type: QSFP28-100GBase-LR-2L QSFP28-100GBase-LR4-2L-IND

Quick Spec:

Form Factor:	QSFP28
TX Wavelength:	1310nm
Reach:	2km
Cable Type:	SMF
Rate Category:	100GBase
Interface Type:	LR4-2L
DDM:	Yes
Connector Type:	Dual-LC
Optical Power Budget:	1.6 dB
TX Power Min/Max:	-6.5 to +2.5 dBm
RX Power Min/Max:	-8.1 to +2.5 dBm



Features:

- Hot pluggable QSFP28 MSA form factor
- Supports 103 Gbps
- Up to 2km reach for G.652 SMF
- Single +3.3V power supply
- Operating case temperature: 0~70°C
- Transmitter: cooled 4x25 Gbps LAN WDM DML TOSA (1295.56, 1300.05, 1304.58, 1309.14nm)
- Receiver: 4x25 Gbps PIN ROSA
- 4x25G Electrical Serial Interface
- Maximum power consumption 3.5W
- RoHS-6 compliant (lead-free)
- Duplex LC receptacle
- I²C interface with integrated Digital Diagnostic Monitoring
- Operating Case Temperature
 - Standard 0 to +70 °C
 - Industrial -40 to +85 °C

Applications:

- 100GBASE-LR4 Ethernet links

Overview

The QSFP28-100GBASE-LR4-2L is a 103 Gbps transceiver module designed for optical communication applications compliant to 100GBASE-LR4-2L of the IEEE P802.3ba standard. The module converts 4 input channels of 25 Gbps electrical data to 4 channels of LAN WDM optical signals and then multiplexes them into a single channel for 103 Gbps optical transmission. Reversely on the receiver side, the module de-multiplexes a 103 Gbps optical input into 4 channels of LAN WDM optical signals and then converts them to 4 output channels of electrical data. The central wavelengths of the 4 LAN WDM channels are 1295.56, 1300.05, 1304.58 and 1309.14 nm as members of the LAN WDM wavelength grid defined in IEEE 802.3ba. The high performance cooled LAN WDM DFB transmitters and high sensitivity PIN receivers provide superior performance for 100G applications up to 2km links and compliant to optical interface with IEEE802.3ba Clause 88 100GBASE-LR4. The product is designed with form factor, optical/electrical connection and digital diagnostic interface according to the QSFP+ Multi-Source Agreement (MSA).

Specification:

Absolute Maximum Ratings

Parameter	Symbol	Min	Max	Unit
Storage Temperature	T_s	-40	+85	°C
Operating Case Temp (Standard)	TOP	0	70	°C
Operating Case Temp (Industrial)	TOP	-40	85	°C
Power Supply Voltage	Vcc	-0.5	3.6	V
Relative Humidity (non-condensation)	RH	5	85	%

Recommended Operating Conditions

Parameter	Symbol	Min	Typ	Max	Unit
Power Supply Voltage	Vcc	3.135	3.3	3.465	V
Data Rate, each Lane			25.78125		Gb/s
Control Input Voltage (High)		2		Vcc	V
Control Input Voltage Low		0		0.8	V
Link Distance (SM fiber)	D			2	km

Recommended Power Supply Filter

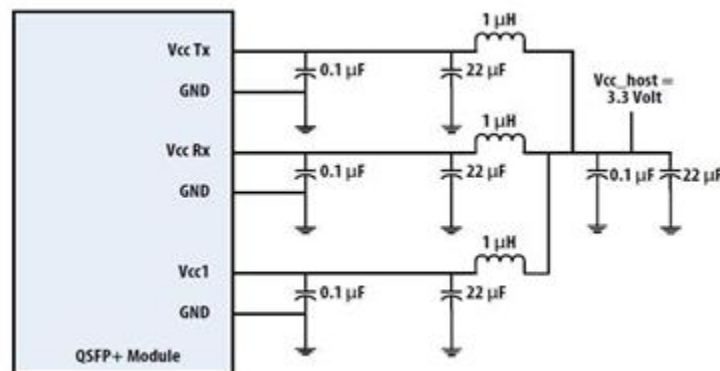

Electrical Characteristics

Parameter	Symbol	Min	Typ	Max	Unit
Power Consumption		-		4.5	W
Supply Current	I_{cc}			1.21	A

Electrical Characteristics-Transmitter (each lane)

Parameter	Symbol	Min	Typ	Max	Unit
Differential Input Voltage Swing	$V_{in,pp}$	150		1200	mVpp
Differential Input Impedance	Z_{in}	85	100	115	Ω

Electrical Characteristics-Receiver

Parameter	Symbol	Min	Typ	Max	Unit
Differential Output Voltage Swing	$V_{out,pp}$	200		1100	mVpp
Differential Output Impedance	Z_{out}	85	100	115	ohm

Optical Characteristics

Parameter	Symbol	Min	Typ	Max	Unit
Lane Wavelength	L_0	1294.53	1295.56	1296.59	nm
	L_1	1299.02	1300.05	1301.09	
	L_2	1303.54	1304.58	1305.63	
	L_3	1308.09	1309.1	1310.19	

Optical Characteristics-Transmitter

Parameter	Symbol	Min	Typ	Max	Unit	Notes
Signaling Speed per Lane	<i>BR</i>		25.78		Gbps	
Side-mode Suppression Ratio	<i>SMSR</i>	30			dB	
Total Average Launch Power	<i>PT</i>			10.5	dBm	
Average Launch Power (each Lane)	<i>PAVG</i>	-4.3		4.5	dBm	
Optical Modulation Amplitude (each Lane)	<i>POMA</i>	-1.3		4.5	dBm	1
Extinction Ratio	<i>ER</i>	4			dB	
Optical Return Loss Tolerance	<i>TOL</i>			20	dB	
Eye Mask [X1, X2, X3, Y1, Y2, Y3]		IEEE 802.3 Clause 88 100GBase-LR4				
Average Launch Power OFF (each Lane)	<i>Poff</i>			-30	dBm	

Optical Characteristics-Receiver

Parameter	Symbol	Min	Typ	Max	Unit	Notes
Signaling Speed per Lane	<i>BR</i>		25.78		Gbps	
Total Average Receive Power				10.5	dBm	
Average Power at Receiver, each Lane		-10.6		4.5	dBm	
Receive Power (OMA) (each Lane)				4.5	dBm	
Receiver Sensitivity (OMA), each Lane	<i>SEN</i>			-8.6	dBm	
LOS Assert	<i>LOSA</i>		-26		dBm	
LOS Deassert	<i>LOSD</i>		-11.6		dBm	
LOS Hysteresis	<i>LOSH</i>	0.5			dB	
Optical Return Loss	<i>ORL</i>	-25			dB	

Digital Diagnostic Functions

The following digital diagnostic characteristics are defined over the normal operating conditions unless otherwise specified.

Parameter	Symbol	Min	Typ	Max	Unit	Notes
Temperature monitor absolute error	<i>DMITEMP</i>	-3		3	deg. C	Over operating temperature range
Supply voltage monitor absolute error	<i>DMIVCC</i>	-0.1		0.1	V	Over Full operating range
Channel RX power monitor absolute error	<i>DMIRX_CH</i>	-2		2	dB	1
Channel Bias current monitor	<i>DMIibias_CH</i>	-10%		10%	mA	
Channel TX power monitor absolute error	<i>DMITX_CH</i>	-2		2	dB	1

PIN Assignment and Function Definitions

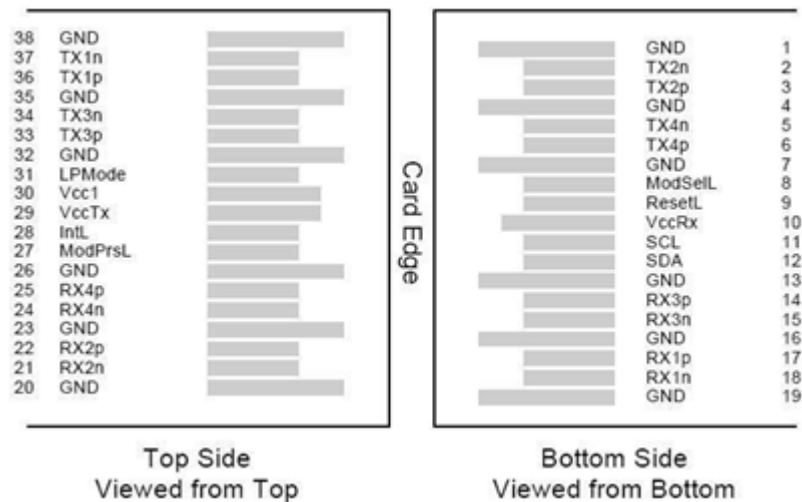

PIN Definition

PIN	Signal Name	Description
1	GND	Ground (1)
2	Tx2n	CML-I Transmitter 2 Inverted Data Input
3	Tx2p	CML-I Transmitter 2 Non-Inverted Data Input
4	GND	Ground (1)
5	Tx4n	CML-I Transmitter 4 Inverted Data Input
6	Tx4p	CML-I Transmitter 4 Non-Inverted Data Input
7	GND	Ground (1)
8	ModSelL	LVTTLL-I Module Select
9	ResetL	LVTTLL-I Module Reset
10	VCCRx	+3.3V Power Supply Receiver (2)
11	SCL	LVCNOS-I/O 2-Wire Serial Interface Clock
12	SDA	LVCNOS-I/O 2-Wire Serial Interface Data
13	GND	Ground (1)
14	Rx3p	CML-O Receiver 3 Non-Inverted Data Output
15	Rx3n	CML-O Receiver 3 Inverted Data Output
16	GND	Ground (1)
17	Rx1p	CML-O Receiver 1 Non-Inverted Data Output
18	Rx1n	CML-O Receiver 1 Inverted Data Output
19	GND	Ground (1)
20	GND	Ground (1)
21	Rx2n	CML-O Receiver 2 Inverted Data Output
22	Rx2p	CML-O Receiver 2 Non-Inverted Data Output
23	GND	Ground (1)
24	Rx4n	CML-O Receiver 4 Inverted Data Output
25	Rx4p	CML-O Receiver 4 Non-Inverted Data Output
26	GND	Ground (1)
27	ModPrsL	Module Present
28	IntL	Interrupt
29	VCCTx	+3.3V Power Supply Transmitter (2)
30	VCC1	+3.3V Power Supply
31	LPMode	LVTTLL-I Low Power Mode
32	GND	Ground (1)
33	Tx3p	CML-I Transmitter 3 Non-Inverted Data Input
34	Tx3n	CML-I Transmitter 3 Inverted Data Input
35	GND	Ground (1)
36	Tx1p	CML-I Transmitter 1 Non-Inverted Data Input
37	Tx1n	CML-I Transmitter 1 Inverted Data Input
38	GND	Ground (1)

Notes:

1. All Ground (GND) are common within the QSFP+ module and all module voltages are referenced to this potential unless noted otherwise. Connect these directly to the host board signal common ground plane.
2. VccRx, Vcc1 and VccTx are the receiving and transmission power suppliers and shall be applied concurrently. The connector pins are each rated for a maximum current of 500mA.